

u-tec[®] UT

Our change system,
that makes EVERYTHING possible

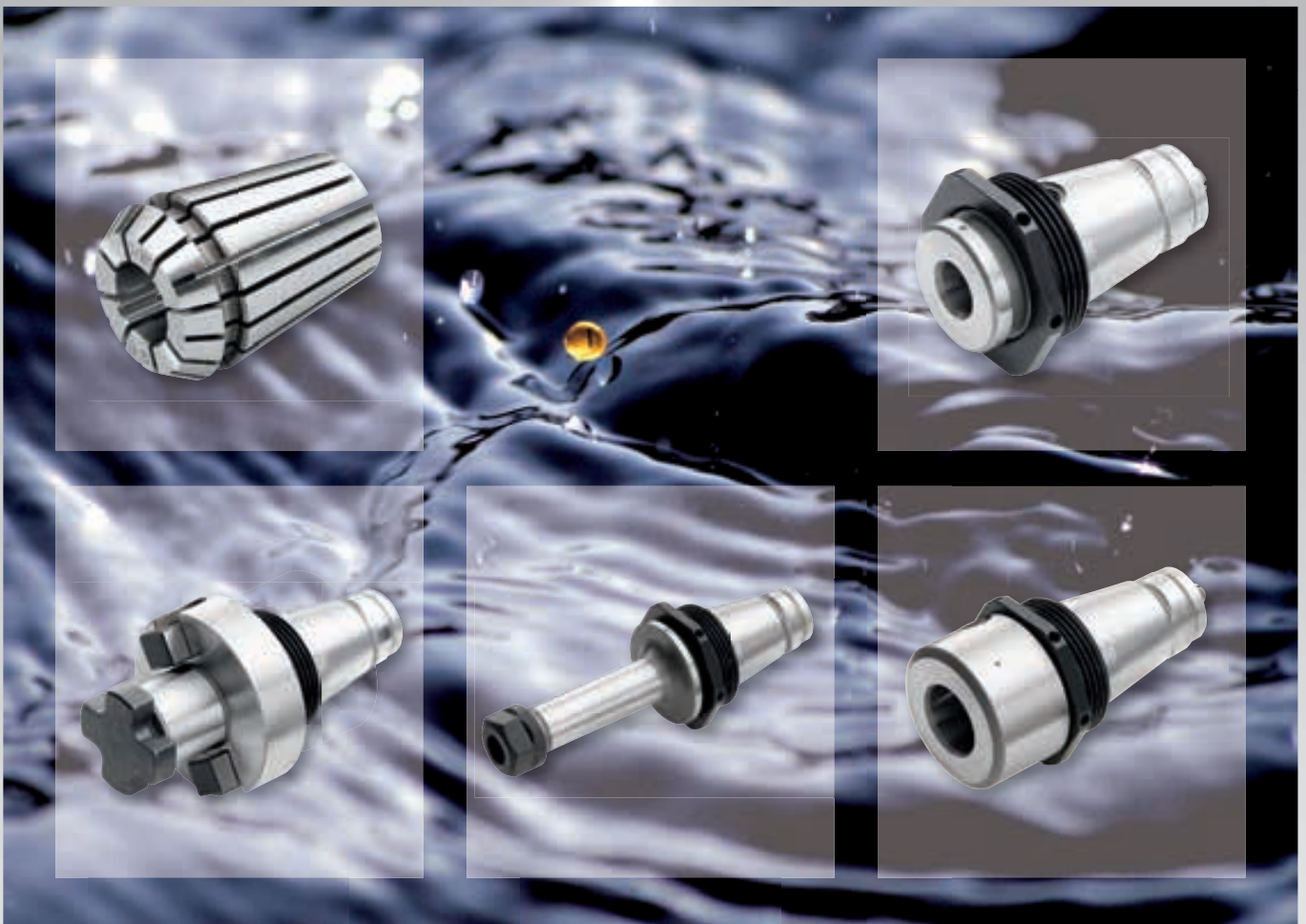



Terms and conditions:

You will find them on our website

www.heimatec.com

Home/Imprint/Terms and Conditions

This catalogue, including all its parts, is protected by copyright. Each use outside the restricted limitations of the Copyright Act is inadmissible and liable to prosecution without the consent of heimatec. This is particularly valid for duplication, translation, microfilming and feeding and processing in electronic systems.

heimatec® GmbH reserves the right of technical changes everytime without advance notice, which is particularly valid for adaptations to new or changed international standards, or to developments of our products or manufacturing processes.

type	page
u-tec info / mounting device UT / description of symbol	2
u-tec UT 16 A	5
u-tec UT 20 A	9
u-tec UT 25 A	13
u-tec UT 32 A	17
u-tec UT 40 A	21
u-tec accessory sheet	25

▶ application types

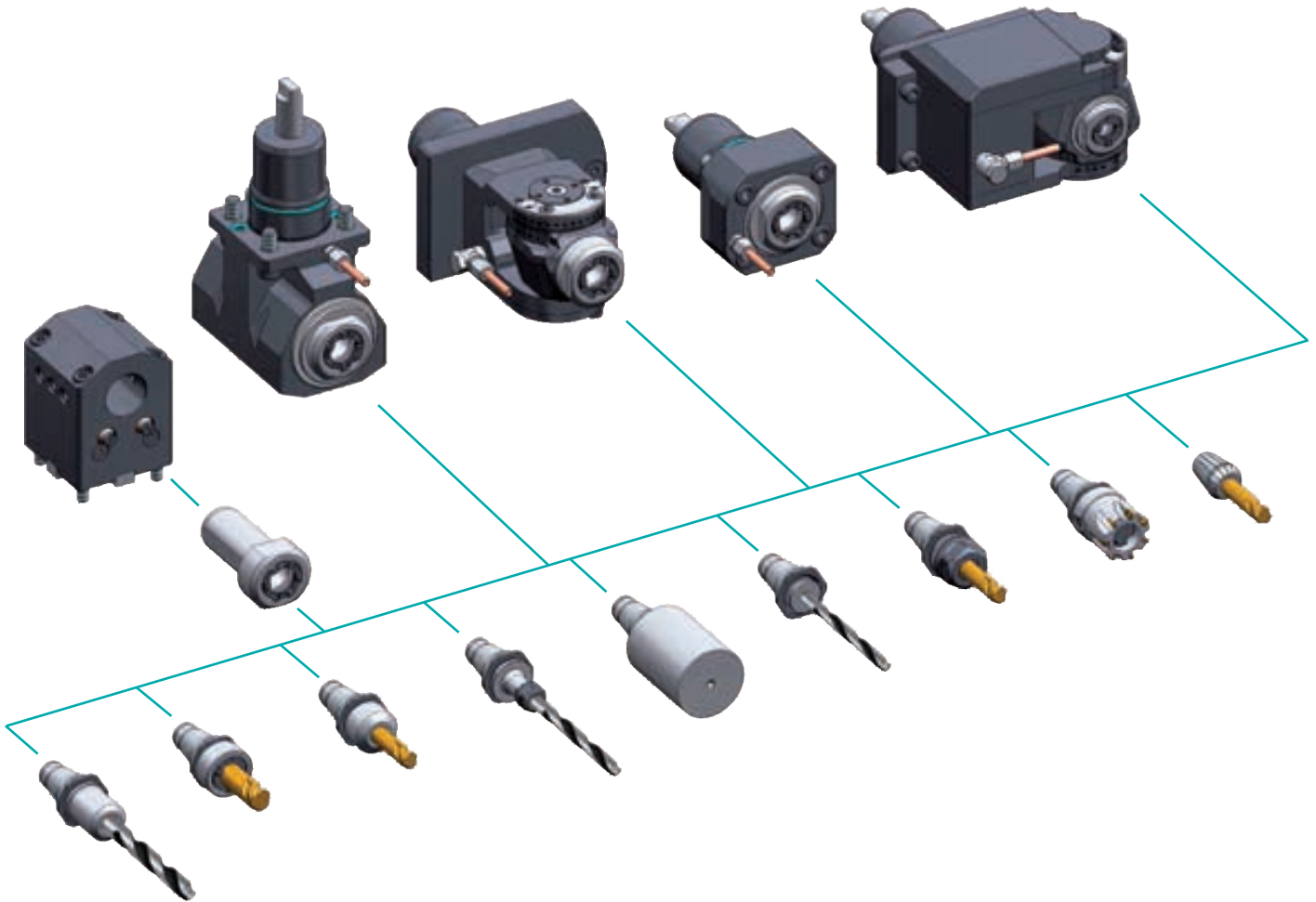

▶ definition of zero

ER 16		ER 20		ER 25		ER 32		ER 40	
X	10	X	11	X	12	X	14	X	16

ER...A

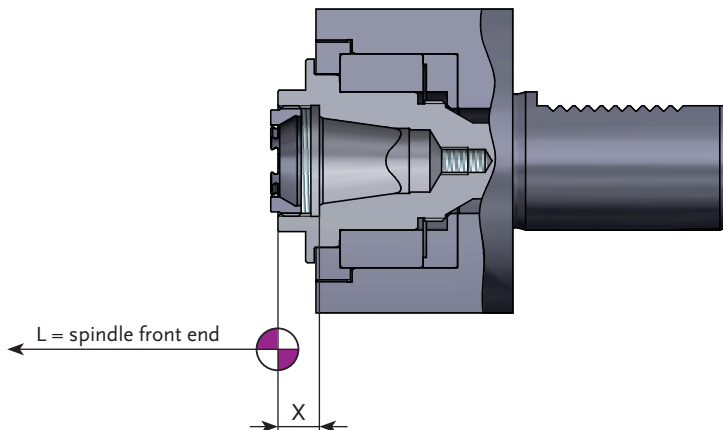

► assembly u-tec

Remove collet nut (1) and store. The u-tec adapter (2) is clamped with a special collet nut (3). Clamp collet nut (3) properly by using a wrench to hold the tool spindle.

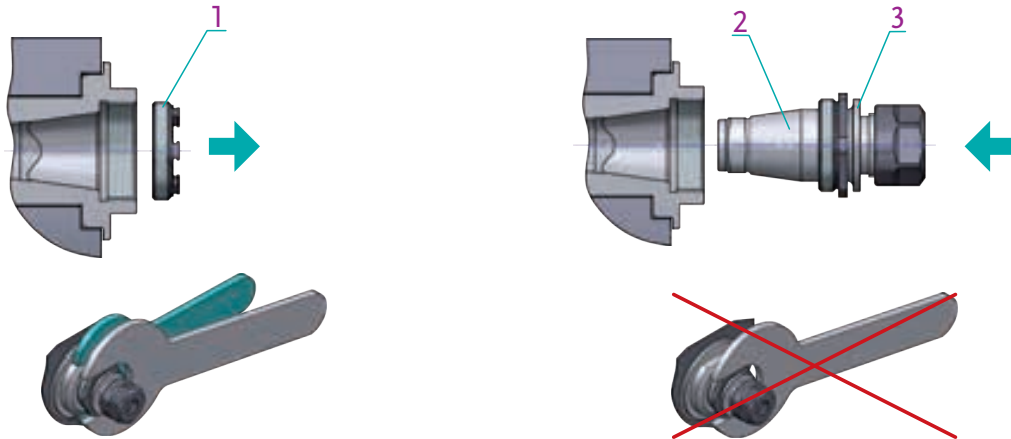

► disassembly u-tec

There are two different disassembling methods.

I: **adapter with impression flange**
Remove collet nut.

II: **adapter without impression flange**
Use special wrench (4).
Remove collet nut together with adapter.

I:

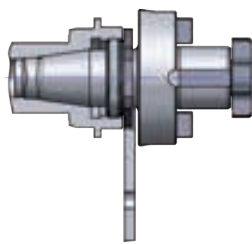

II:

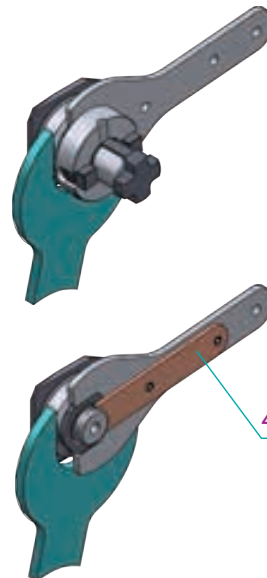
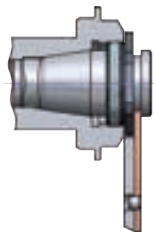

recommended clamping torque for UT clamping nut

UT 16	UT 20	UT 25	UT 32	UT 40
40 Nm	55 Nm	60 Nm	80 Nm	100 Nm

Warning ! The maximum clamping torque should not extend more than 15% of the recommended clamp torque.

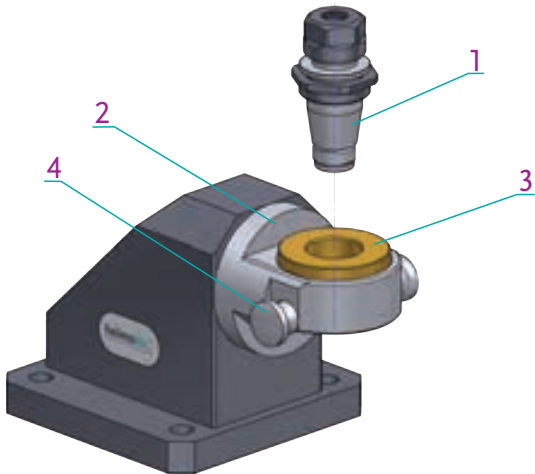

► mounting device

mounting device UT 8 710 95 001

For mounting cutters in various adaptors (1). Please place mounting device safely, in vice or mount on bench. The attachment (2) can be adjusted in 30° steps. The holding fixture (3) is held by locator pin (4). (left and right side operation)



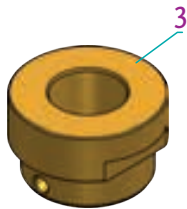

More holding fixtures (3) available as options for adaptors (1) in various sizes and types.







► interchangeable bushings (3) available:

- UT 16 - 8 732 54 005
- UT 20 - 8 732 54 006
- UT 25 - 8 732 55 004
- UT 32 - 8 732 56 004
- UT 40 - 8 732 57 003

► description of symbol

symbols	accessory sheet
 ZB 655 ...*	set of wrenches
 ZB ER ...*	collets ER-DIN 6499
 ZB ET ...*	tapping collets ET-DIN 6499
 ZB GB ...*	tapping collets GB
 ZB 741 ...*	seal disks

symbols	accessory sheet
 ZB 620 ...*	milling arbor spacers
 ZB HT ...*	easy-quick
 ZB UT ...*	u-tec
 ZB 776 ...*	collet chuck
 ZB 73 ...*	reducing sleeves

► further versions on request

* not included in delivery

u-tec[®]



UT 16

▶ interface: UT 16 A

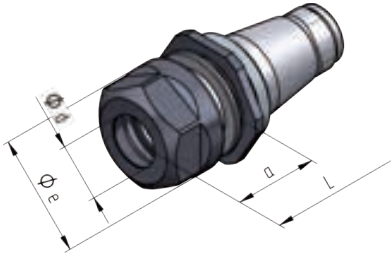

▶ collet chuck

clamping system	ref.-no.	ø d [mm]	ø e [mm]	a [mm]	L [mm]
ER 11	8 779 43 005	0,5 - 7,0	19,0	14,1	21,5
ER 16	8 779 44 012	0,5 - 10,0	28,0	22,5	30,0

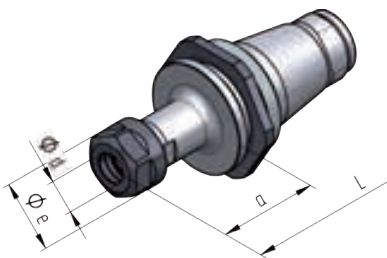

▶ collet chuck long

clamping system	ref.-no.	ø d [mm]	ø e [mm]	a [mm]	L [mm]
ER 11	8 779 43 014	0,5 - 7,0	19,0	22,5	30,0
ER 11	8 779 43 015	0,5 - 7,0	19,0	52,5	60,0

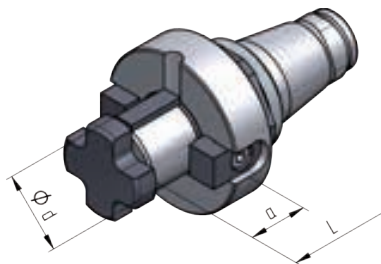

▶ arbor

clamping system	ref.-no.	ø d [mm]	a [mm]	L [mm]
arbor 13	8 779 43 022	13,0	21,0	34,0
universal arbor 16	8 779 44 017	16,0	17,0	34,0
universal arbor ½"	8 779 43 020	½"	14,3	29,5

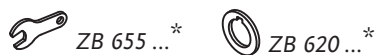

symbolic drawing

▶ further versions on request

* not included in delivery

ZB UT16 4 000

▶ interface: UT 16 A

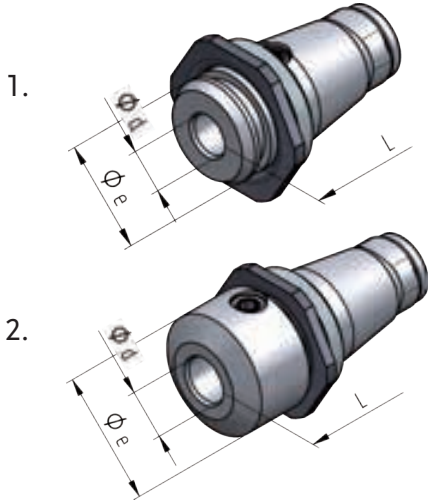

▶ Weldon

clamping system	ref.-no.	$\varnothing d$ [mm]	$\varnothing e$ [mm]	L [mm]	figure
Weldon 6	8 779 42 011	6,0	16,0	11,0	1
Weldon 8	8 779 43 016	8,0	24,0	22,5	2
Weldon 10	8 779 44 013	10,0	26,0	22,5	2
Weldon ¼"	8 779 42 013	¼"	16,0	11,0	1
Weldon ⅜"	8 779 43 018	⅜"	26,0	22,5	2

 ZB 655 ...*

▶ further dimension from $\varnothing d=3$ mm on request

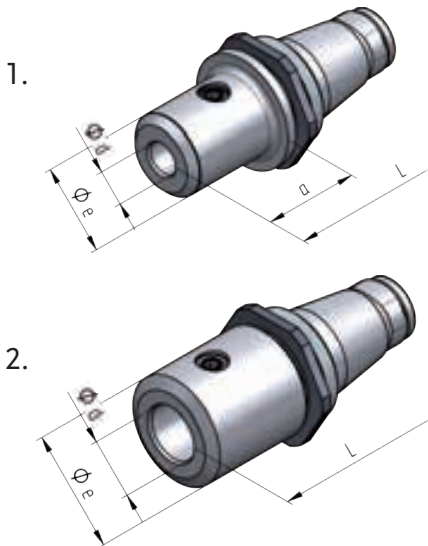

▶ Weldon long

clamping system	ref.-no.	$\varnothing d$ [mm]	$\varnothing e$ [mm]	a [mm]	L [mm]	figure
Weldon 6	8 779 42 012	6,0	16,0	25,0	33,0	1
Weldon 8	8 779 43 017	8,0	24,0	-	33,0	2
Weldon 10	8 779 44 014	10,0	26,0	-	33,0	2
Weldon ¼"	8 779 42 014	¼"	16,0	25,0	33,0	1
Weldon ⅜"	8 779 43 019	⅜"	26,0	-	33,0	2

 ZB 655 ...*

▶ further dimension from $\varnothing d=3$ mm on request



symbolic drawing

▶ further versions on request

* not included in delivery

ZB UT16 4 000

▶ interface: UT 16 A

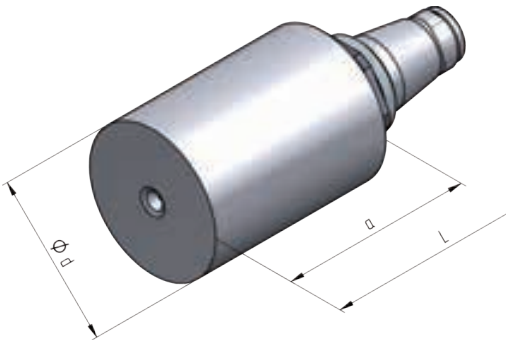

▶ blank

ref.-no.	$\varnothing d$ [mm]	a [mm]	L [mm]
8 779 49 002	41,0	62,9	100,0

 ZB 655 ...*

● material: 25 CrMo 4

hardening temperature: 840-870°C ; coolant: Polymer ; tempering: 1 hour 200°C ;
partial hardening if necessary: induction-hardening is possible
max. hardness which can be attained with this material ~ HV 470

u-tec UT 16

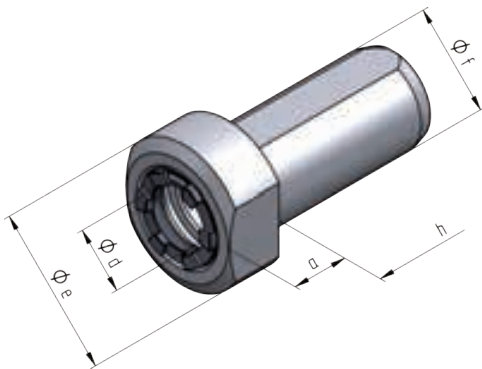

▶ collet chuck

clamping system	ref.-no.	$\varnothing d$ [mm]	$\varnothing e$ [mm]	$\varnothing f$ [mm]	a [mm]	h [mm]
ER 16 AX	8 776 14 004	0,5 - 10,0	38,0	20,0	20,0	65,0
ER 16 AX	8 776 24 005	0,5 - 10,0	38,0	25,0	13,0	65,0
ER 16 AX	8 776 24 007	0,5 - 10,0	38,0	3/4"	22,0	65,0

 ZB 655 ...*

 ZB ER ...*

 ZB ET ...*

 ZB GB ...*

 ZB 741 ...*



▶ locking nut

ref.-no.
8 745 99 000

 ZB 655 ...*



symbolic drawing

▶ further versions on request

* not included in delivery

ZB UT16 4 000

u-tec[®]



UT 20

▶ interface: UT 20 A

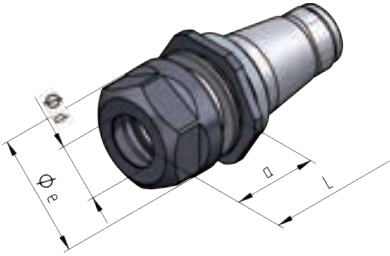

▶ collet chuck

clamping system	ref.-no.	ø d [mm]	ø e [mm]	a [mm]	L [mm]
ER 11	8 779 43 006	0,5 - 7,0	19,0	14,1	22,5
ER 16	8 779 44 001	0,5 - 10,0	28,0	22,5	31,0
ER 20	8 779 44 002	0,5 - 13,0	34,0	24,0	32,5



▶ collet chuck long

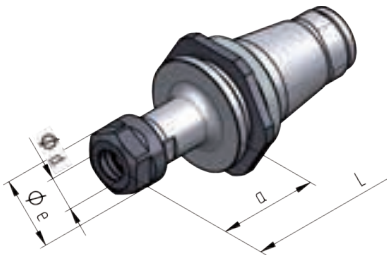

clamping system	ref.-no.	ø d [mm]	ø e [mm]	a [mm]	L [mm]
ER 11	8 779 43 007	0,5 - 7,0	19,0	21,5	30,0
ER 11	8 779 43 008	0,5 - 7,0	19,0	51,5	60,0



▶ arbor

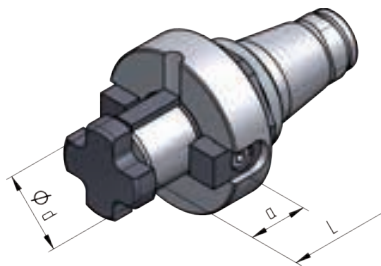

clamping system	ref.-no.	ø d [mm]	a [mm]	L [mm]
arbor 13	8 779 43 023	13,0	21,0	34,5
universal arbor 16	8 779 44 011	16,0	17,0	34,5
universal arbor 22	8 779 45 001	22,0	19,0	38,5
universal arbor ½"	8 779 43 013	½"	14,3	30,0

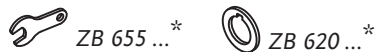

symbolic drawing

▶ further versions on request

* not included in delivery

ZB UT20 4 000

▶ interface: UT 20 A

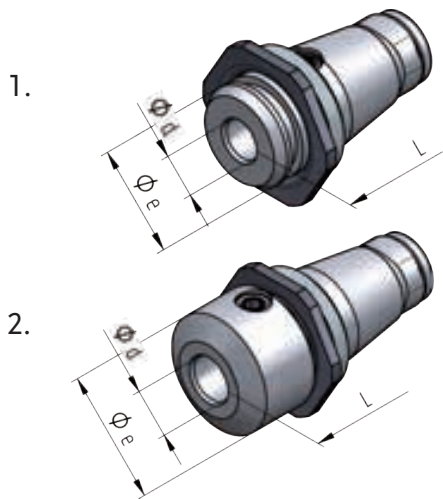

▶ Weldon

clamping system	ref.-no.	ϕd [mm]	ϕe [mm]	L [mm]	figure
Weldon 6	8 779 42 007	6,0	20,0	10,0	1
Weldon 8	8 779 43 009	8,0	20,0	10,0	1
Weldon 10	8 779 44 003	10,0	27,0	23,5	2
Weldon 12	8 779 44 005	12,0	27,0	26,0	2
Weldon ¼"	8 779 42 009	¼"	20,0	10,0	1
Weldon ⅜"	8 779 43 011	⅜"	27,0	23,5	2
Weldon ½"	8 779 44 008	½"	27,0	26,0	2

ZB 655 ...*

▶ further dimension from $\phi d=3$ mm on request

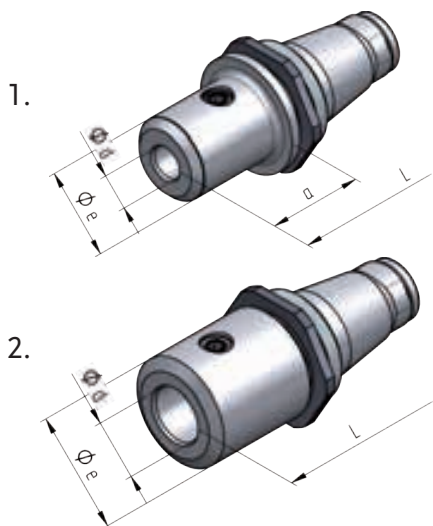

▶ Weldon long

clamping system	ref.-no.	ϕd [mm]	ϕe [mm]	a [mm]	L [mm]	figure
Weldon 6	8 779 42 008	6,0	16,0	24,0	33,0	1
Weldon 8	8 779 43 010	8,0	24,0	24,0	33,0	1
Weldon 10	8 779 44 004	10,0	27,0	-	33,0	2
Weldon 12	8 779 44 006	12,0	27,0	-	33,0	2
Weldon ¼"	8 779 42 010	¼"	16,0	24,0	33,0	1
Weldon ⅜"	8 779 43 012	⅜"	27,0	-	33,0	2
Weldon ½"	8 779 44 009	½"	27,0	-	33,0	2

ZB 655 ...*

▶ further dimension from $\phi d=3$ mm on request



symbolic drawing

▶ further versions on request

* not included in delivery

ZB UT20 4 000

▶ interface: UT 20 A

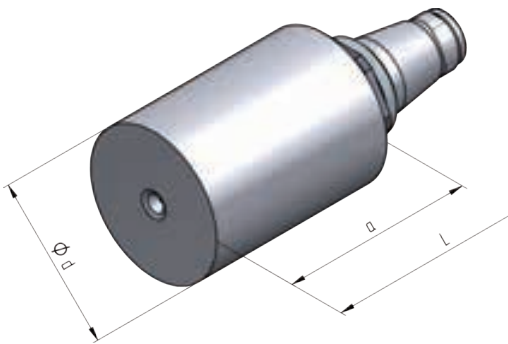

▶ blank

ref.-no.	ø d [mm]	a [mm]	L [mm]
8 779 49 003	51,0	59,5	105,0

ZB 655 ...*

● material: 25 CrMo 4

hardening temperature: 840-870°C ; coolant: Polymer ; tempering: 1 hour 200°C ;
partial hardening if necessary: induction-hardening is possible,
max. hardness which can be attained with this material ~ HV 470

u-tec UT 20

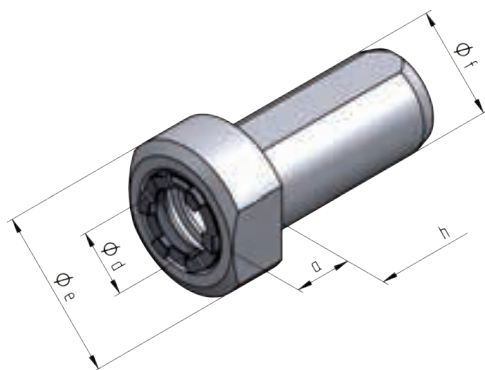

▶ collet chuck

clamping system	ref.-no.	ø d [mm]	ø e [mm]	ø f [mm]	a [mm]	h [mm]
ER 20 AX	8 776 24 006	0,5 - 13,0	42,0	25,0	17,0	65,0
ER 20 AX	8 776 34 004	0,5 - 13,0	42,0	32,0	14,0	65,0
ER 20 AX	8 776 24 008	0,5 - 13,0	42,0	1"	17,0	65,0

ZB 655 ...*

ZB ER ...*

ZB ET ...*

ZB GB ...*

ZB 741 ...*



▶ locking nut

ref.-no.
8 745 99 001

ZB 655 ...*



symbolic drawing

▶ further versions on request

* not included in delivery

ZB UT20 4 000

u-tec[®]



UT 25

▶ interface: UT 25 A

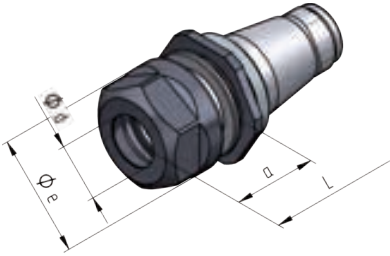

▶ collet chuck

clamping system	ref.-no.	ø d [mm]	ø e [mm]	a [mm]	L [mm]
ER 16	8 779 54 013	0,5 - 10,0	28,0	22,5	31,0
ER 20	8 779 54 018	0,5 - 13,0	34,0	24,0	32,5
ER 25	8 779 55 005	0,5 - 16,0	42,0	25,0	34,5

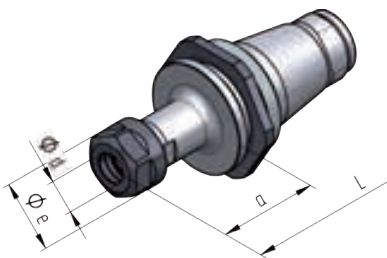

▶ collet chuck long

clamping system	ref.-no.	ø d [mm]	ø e [mm]	a [mm]	L [mm]
ER 11	8 779 53 014	0,5 - 7,0	19,0	31,0	40,0
ER 11	8 779 53 015	0,5 - 7,0	19,0	61,0	70,0

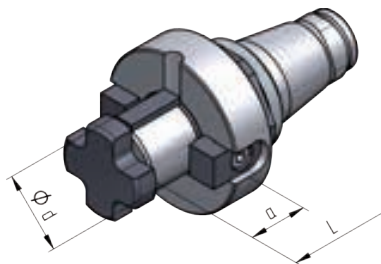

▶ arbor

clamping system	ref.-no.	ø d [mm]	a [mm]	L [mm]
arbor 13	8 779 53 010	13,0	21,0	34,5
universal arbor 16	8 779 54 020	16,0	17,0	34,5
universal arbor 22	8 779 55 001	22,0	19,0	38,5
universal arbor 27	8 779 56 001	27,0	21,0	42,5
universal arbor ½"	8 779 53 022	½"	14,3	30,0
universal arbor ¾"	8 779 54 041	¾"	17,45	36,0

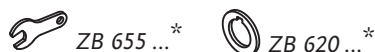

symbolic drawing

▶ further versions on request

* not included in delivery

ZB UT25 5 000

▶ interface: UT 25 A

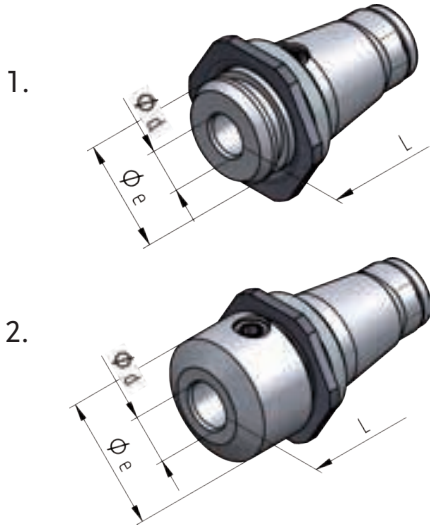

▶ Weldon

clamping system	ref.-no.	$\varnothing d$ [mm]	$\varnothing e$ [mm]	L [mm]	figure
Weldon 6	8 779 52 008	6,0	25,0	9,0	1
Weldon 8	8 779 53 016	8,0	25,0	9,0	1
Weldon 10	8 779 54 025	10,0	25,0	11,0	1
Weldon 12	8 779 54 022	12,0	32,0	26,0	2
Weldon 14	8 779 54 024	14,0	32,0	26,0	2
Weldon 16	8 779 55 003	16,0	32,0	26,0	2
Weldon ¼"	8 779 52 012	¼"	25,0	9,0	1
Weldon ⅜"	8 779 53 018	⅜"	25,0	11,0	1
Weldon ½"	8 779 54 037	½"	32,0	26,0	2
Weldon ⅝"	8 779 54 039	⅝"	32,0	26,0	2

ZB 655 ...*

▶ further dimension from $\varnothing d=3$ mm on request

▶ Weldon long

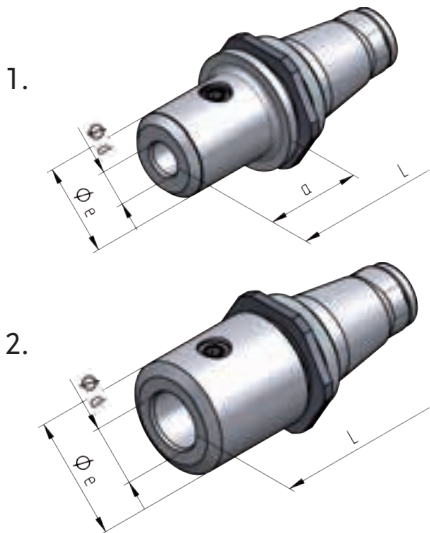

clamping system	ref.-no.	$\varnothing d$ [mm]	$\varnothing e$ [mm]	a [mm]	L [mm]	figure
Weldon 6	8 779 52 010	6,0	16,0	31,0	40,0	1
Weldon 8	8 779 53 020	8,0	24,0	31,0	40,0	1
Weldon 10	8 779 54 027	10,0	26,0	31,0	40,0	1
Weldon 12	8 779 54 029	12,0	28,0	31,0	40,0	1
Weldon 14	8 779 54 031	14,0	30,0	31,0	40,0	1
Weldon 16	8 779 55 007	16,0	32,0	-	40,0	2
Weldon ¼"	8 779 52 014	¼"	16,0	31,0	40,0	1
Weldon ⅜"	8 779 53 024	⅜"	26,0	31,0	40,0	1
Weldon ½"	8 779 54 033	½"	28,0	31,0	40,0	1
Weldon ⅝"	8 779 54 035	⅝"	32,0	-	40,0	2

ZB 655 ...*

▶ further dimension from $\varnothing d=3$ mm on request



symbolic drawing

▶ further versions on request

* not included in delivery

ZB UT25 5 000

▶ interface: UT 25 A

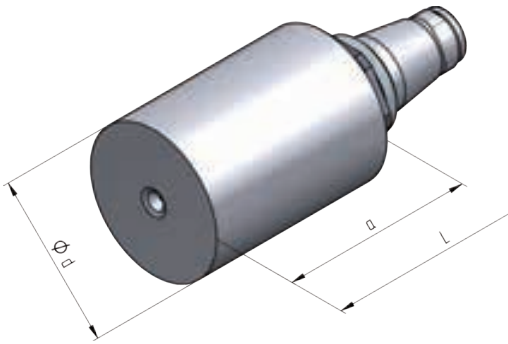

▶ blank

ref.-no.	ø d [mm]	a [mm]	L [mm]
8 779 59 003	52,0	70,0	120,0

 ZB 655 ...*

● material: 25 CrMo 4

hardening temperature: 840-870°C ; coolant: Polymer ; tempering: 1 hour 200°C ;
partial hardening if necessary: induction-hardening is possible,
max. hardness which can be attained with this material ~ HV 470

u-tec UT 25

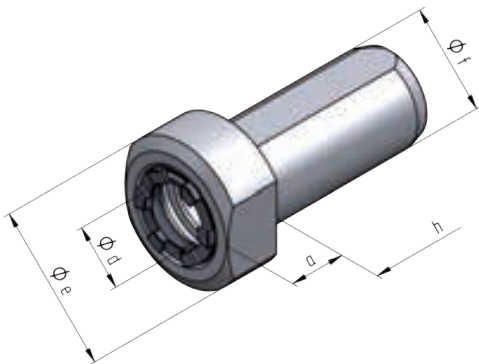

▶ collet chuck

clamping system	ref.-no.	ø d [mm]	ø e [mm]	ø f [mm]	a [mm]	h [mm]
ER 25 AX	8 776 25 009	0,5 - 16,0	48,0	25,0	35,0	65,0
ER 25 AX	8 776 35 003	0,5 - 16,0	48,0	32,0	20,0	65,0
ER 25 AX	8 776 45 002	0,5 - 16,0	48,0	40,0	15,0	65,0
ER 25 AX	8 776 25 010	0,5 - 16,0	48,0	1"	35,0	65,0
ER 25 AX	8 776 25 011	0,5 - 16,0	48,0	1¼"	20,0	65,0

 ZB 655 ...*

 ZB ER ...*

 ZB ET ...*

 ZB GB ...*

 ZB 741 ...*



▶ locking nut

ref.-no.
8 745 99 002

 ZB 655 ...*



symbolic drawing

▶ further versions on request

* not included in delivery

ZB UT25 5 000

u-tec[®]



UT32

▶ interface: UT 32 A

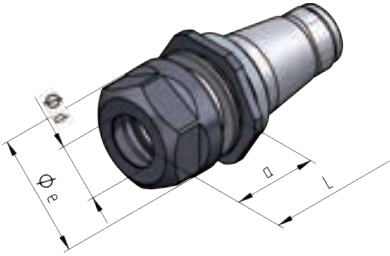

▶ collet chuck

clamping system	ref.-no.	ø d [mm]	ø e [mm]	a [mm]	L [mm]
ER 16	8 779 64 039	0,5 - 10,0	28,0	22,5	32,5
ER 20	8 779 64 040	0,5 - 13,0	34,0	24,0	34,0
ER 25	8 779 65 010	0,5 - 16,0	42,0	25,0	35,0
ER 32	8 779 66 001	1,0 - 20,0	50,0	27,5	43,0



▶ collet chuck long

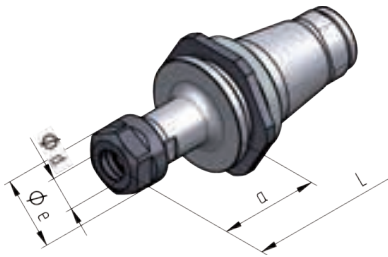

clamping system	ref.-no.	ø d [mm]	ø e [mm]	a [mm]	L [mm]
ER 11	8 779 63 018	0,5 - 7,0	19,0	35,0	45,0
ER 11	8 779 63 019	0,5 - 7,0	19,0	65,0	75,0
ER 16	8 779 64 041	0,5 - 10,0	28,0	35,0	45,0
ER 16	8 779 64 042	0,5 - 10,0	28,0	65,0	75,0



▶ arbor

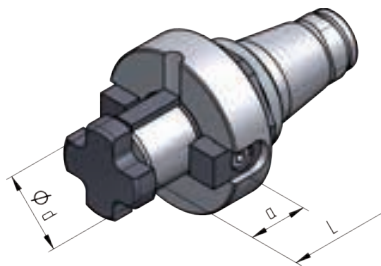

clamping system	ref.-no.	ø d [mm]	a [mm]	L [mm]
universal arbor 16	8 779 64 049	16,0	17,0	35,5
universal arbor 22	8 779 65 015	22,0	19,0	38,5
universal arbor 27	8 779 66 004	27,0	21,0	43,5
universal arbor ½"	8 779 63 024	½"	14,3	31,0
universal arbor ¾"	8 779 64 054	¾"	17,45	37,0



symbolic drawing

▶ further versions on request

* not included in delivery

ZB UT32 6 000

▶ interface: UT 32 A

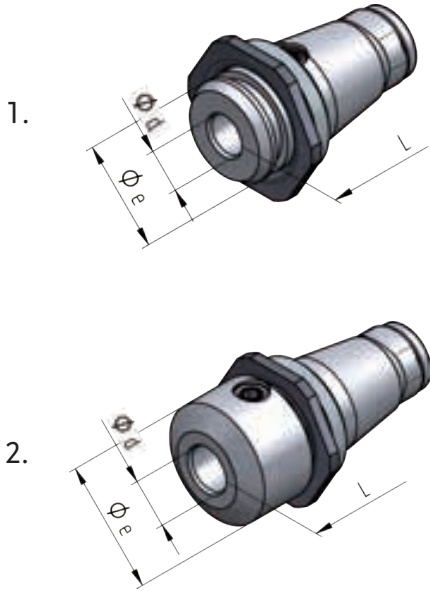

▶ Weldon

clamping system	ref.-no.	$\varnothing d$ [mm]	$\varnothing e$ [mm]	L [mm]	figure
Weldon 6	8 779 62 017	6,0	32,0	10,5	1
Weldon 8	8 779 63 020	8,0	32,0	11,5	1
Weldon 10	8 779 64 043	10,0	32,0	11,5	1
Weldon 12	8 779 64 044	12,0	32,0	14,0	1
Weldon 14	8 779 64 045	14,0	32,0	14,0	1
Weldon 16	8 779 65 011	16,0	32,0	14,0	1
Weldon 18	8 779 65 012	18,0	39,0	28,0	2
Weldon 20	8 779 66 002	20,0	39,0	28,0	2
Weldon ¼"	8 779 62 019	¼"	32,0	10,5	1
Weldon ⅜"	8 779 63 022	⅜"	32,0	11,5	1
Weldon ½"	8 779 64 050	½"	32,0	14,0	1
Weldon ⅝"	8 779 64 051	⅝"	32,0	14,0	1
Weldon ¾"	8 779 65 016	¾"	39,0	28,0	2

ZB 655 ...*

▶ further dimension from $\varnothing d=3$ mm on request

▶ Weldon long

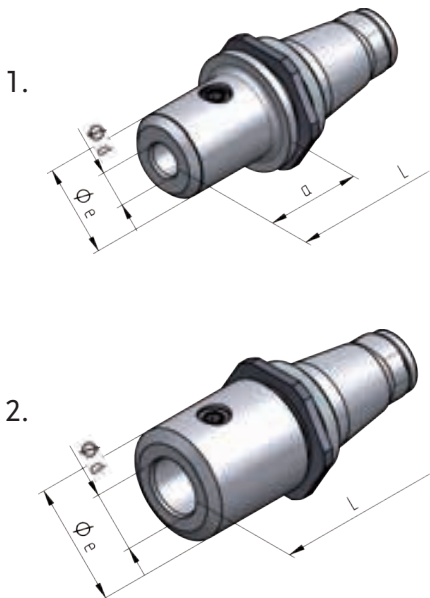

clamping system	ref.-no.	$\varnothing d$ [mm]	$\varnothing e$ [mm]	a [mm]	L [mm]	figure
Weldon 6	8 779 62 018	6,0	16,0	30,0	40,0	1
Weldon 8	8 779 63 021	8,0	24,0	30,0	40,0	1
Weldon 10	8 779 64 046	10,0	26,0	30,0	40,0	1
Weldon 12	8 779 64 047	12,0	28,0	30,0	40,0	1
Weldon 14	8 779 64 048	14,0	30,0	30,0	40,0	1
Weldon 16	8 779 65 013	16,0	32,0	30,0	40,0	1
Weldon 18	8 779 65 014	18,0	34,0	30,0	40,0	1
Weldon 20	8 779 66 003	20,0	39,0	-	40,0	2
Weldon ¼"	8 779 62 020	¼"	16,0	30,0	40,0	1
Weldon ⅜"	8 779 63 023	⅜"	26,0	30,0	40,0	1
Weldon ½"	8 779 64 052	½"	28,0	30,0	40,0	1
Weldon ⅝"	8 779 64 053	⅝"	32,0	30,0	40,0	1
Weldon ¾"	8 779 65 017	¾"	39,0	-	40,0	2

ZB 655 ...*

▶ further dimension from $\varnothing d=3$ mm on request



symbolic drawing

▶ further versions on request

* not included in delivery

ZB UT32 6 000

▶ interface: UT 32 A

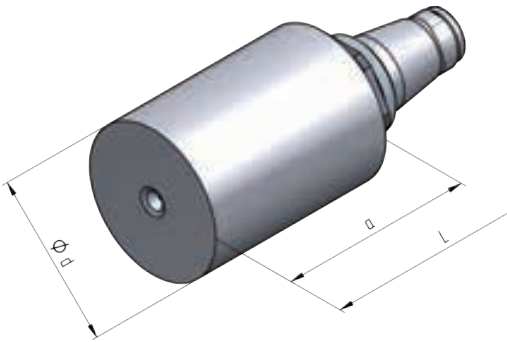

▶ blank

ref.-no.	ø d [mm]	a [mm]	L [mm]
8 779 69 011	52,0	73,5	130,0

 ZB 655 ...*

- material: 25 CrMo 4
hardening temperature: 840-870°C ; coolant: Polymer ; tempering: 1 hour 200°C ;
partial hardening if necessary: induction-hardening is possible,
max. hardness which can be attained with this material ~ HV 470

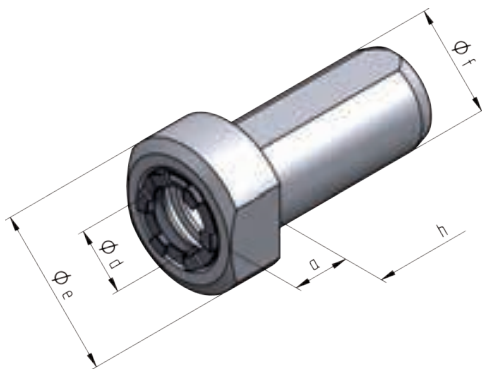

▶ collet chuck

clamping system	ref.-no.	ø d [mm]	ø e [mm]	ø f [mm]	a [mm]	h [mm]
ER 32 AX	8 776 36 004	1,0 - 20,0	58,0	32,0	40,0	65,0
ER 32 AX	8 776 46 003	1,0 - 20,0	58,0	40,0	20,0	65,0
ER 32 AX	8 776 26 003	1,0 - 20,0	58,0	1¼"	46,0	65,0
ER 32 AX	8 776 36 005	1,0 - 20,0	58,0	1½"	20,0	65,0

 ZB 655 ...*  ZB ER ...*  ZB ET ...*  ZB GB ...*
 ZB 741 ...*



▶ locking nut

ref.-no.
8 745 99 003

 ZB 655 ...*



symbolic drawing

▶ further versions on request

* not included in delivery

ZB UT32 6 000

u-tec[®]



UT 40

▶ interface: UT 40 A

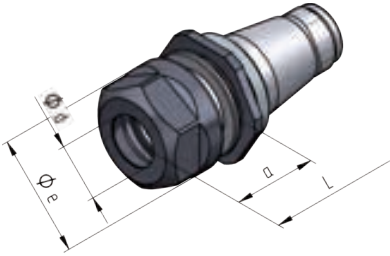

▶ collet chuck

clamping system	ref.-no.	ø d [mm]	ø e [mm]	a [mm]	L [mm]
ER 16	8 779 74 027	0,5 - 10,0	28,0	22,5	34,0
ER 20	8 779 74 028	0,5 - 13,0	34,0	24,0	35,5
ER 25	8 779 75 014	0,5 - 16,0	42,0	25,0	36,5
ER 32	8 779 76 008	1,0 - 20,0	50,0	27,5	39,0
ER 40	8 779 77 001	2,0 - 30,0	63,0	30,5	48,0



▶ collet chuck long

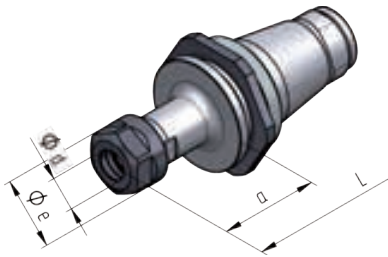

clamping system	ref.-no.	ø d [mm]	ø e [mm]	a [mm]	L [mm]
ER 11	8 779 73 006	0,5 - 7,0	19,0	48,0	60,0
ER 11	8 779 73 007	0,5 - 7,0	19,0	68,0	80,0
ER 16	8 779 74 029	0,5 - 10,0	28,0	48,0	60,0
ER 16	8 779 74 030	0,5 - 10,0	28,0	68,0	80,0
ER 20	8 779 74 031	0,5 - 13,0	34,0	48,0	60,0
ER 20	8 779 74 032	0,5 - 13,0	34,0	68,0	80,0
ER 25	8 779 75 015	0,5 - 16,0	42,0	48,0	60,0
ER 25	8 779 75 016	0,5 - 16,0	42,0	68,0	80,0



▶ arbor

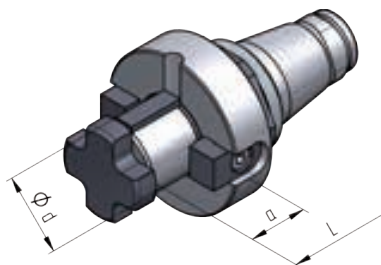

clamping system	ref.-no.	ø d [mm]	a [mm]	L [mm]
universal arbor 16	8 779 74 043	16,0	17,0	36,5
universal arbor 22	8 779 75 023	22,0	19,0	39,5
universal arbor 27	8 779 76 011	27,0	21,0	44,5
universal arbor ½"	8 779 73 012	½"	14,3	32,0
universal arbor ¾"	8 779 74 044	¾"	17,45	38,0

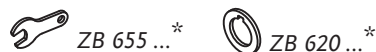

symbolic drawing

▶ further versions on request

* not included in delivery

ZB UT40 7 000

▶ interface: UT 40 A

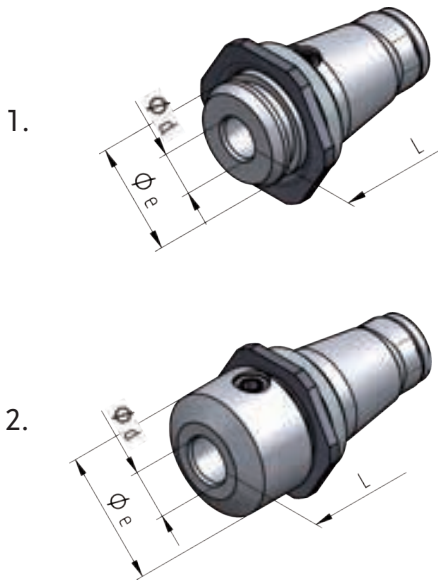

▶ Weldon

clamping system	ref.-no.	$\varnothing d$ [mm]	$\varnothing e$ [mm]	L [mm]	figure
Weldon 6	8 779 72 008	6,0	40,0	11,5	1
Weldon 8	8 779 73 008	8,0	40,0	11,5	1
Weldon 10	8 779 74 033	10,0	40,0	11,5	1
Weldon 12	8 779 74 034	12,0	40,0	12,5	1
Weldon 14	8 779 74 035	14,0	40,0	12,5	1
Weldon 16	8 779 75 017	16,0	40,0	12,5	1
Weldon 18	8 779 75 018	18,0	40,0	13,5	1
Weldon 20	8 779 76 009	20,0	40,0	13,5	1
Weldon 25	8 779 77 002	25,0	47,0	32,0	2
Weldon ¼"	8 779 72 010	¼"	40,0	11,5	1
Weldon ⅜"	8 779 73 010	⅜"	40,0	11,5	1
Weldon ½"	8 779 74 039	½"	40,0	12,5	1
Weldon ⅝"	8 779 74 040	⅝"	40,0	12,5	1
Weldon ¾"	8 779 75 021	¾"	40,0	13,5	1
Weldon 1"	8 779 77 004	1"	47,0	32,0	2

ZB 655 ...*

▶ further dimension from $\varnothing d=3$ mm on request

▶ Weldon long

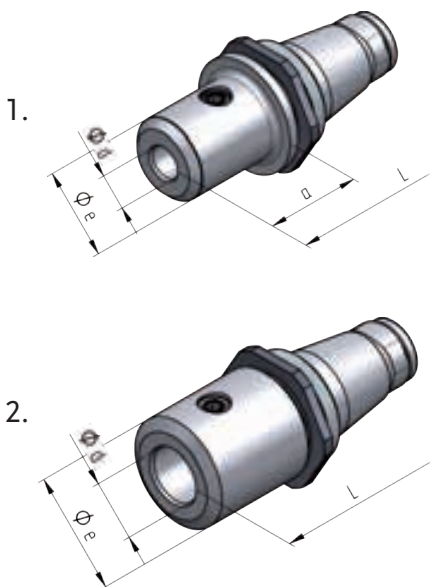

clamping system	ref.-no.	$\varnothing d$ [mm]	$\varnothing e$ [mm]	a [mm]	L [mm]	figure
Weldon 6	8 779 72 009	6,0	16,0	28,0	40,0	1
Weldon 8	8 779 73 009	8,0	24,0	28,0	40,0	1
Weldon 10	8 779 74 036	10,0	26,0	28,0	40,0	1
Weldon 12	8 779 74 037	12,0	28,0	28,0	40,0	1
Weldon 14	8 779 74 038	14,0	30,0	28,0	40,0	1
Weldon 16	8 779 75 019	16,0	32,0	28,0	40,0	1
Weldon 18	8 779 75 020	18,0	34,0	28,0	40,0	1
Weldon 20	8 779 76 010	20,0	39,0	28,0	40,0	1
Weldon 25	8 779 77 003	25,0	47,0	-	40,0	2
Weldon ¼"	8 779 72 011	¼"	16,0	28,0	40,0	1
Weldon ⅜"	8 779 73 011	⅜"	26,0	28,0	40,0	1
Weldon ½"	8 779 74 041	½"	28,0	28,0	40,0	1
Weldon ⅝"	8 779 74 042	⅝"	32,0	28,0	40,0	1
Weldon ¾"	8 779 75 022	¾"	39,0	28,0	40,0	1
Weldon 1"	8 779 77 005	1"	47,0	-	40,0	2

ZB 655 ...*

▶ further dimension from $\varnothing d=3$ mm on request



symbolic drawing

▶ further versions on request

* not included in delivery

ZB UT40 7 000

interface: UT 40 A

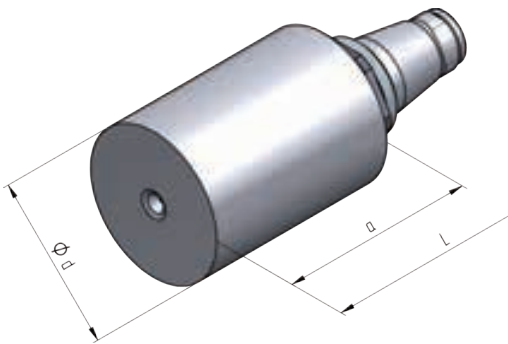

▶ blank

ref.-no.	$\varnothing d$ [mm]	a [mm]	L [mm]
8 779 79 004	52,0	73,5	130,0

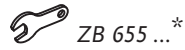

● material: 25 CrMo 4

hardening temperature: 840-870°C ; coolant: Polymer ; tempering: 1 hour 200°C ;
partial hardening if necessary: induction-hardening is possible
max. hardness which can be attained with this material ~ HV 470

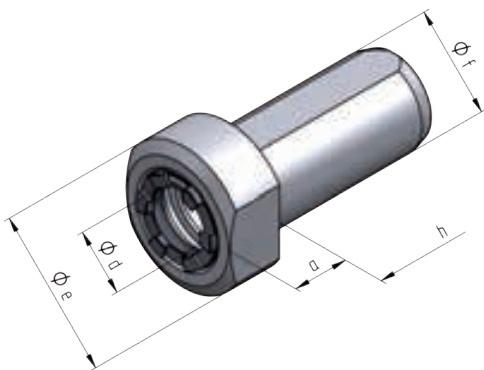

▶ collet chuck

clamping system	ref.-no.	$\varnothing d$ [mm]	$\varnothing e$ [mm]	$\varnothing f$ [mm]	a [mm]	h [mm]
ER 40 AX	8 776 47 003	2,0 - 30,0	75,0	40,0	45,0	65,0
ER 40 AX	8 776 57 002	2,0 - 30,0	75,0	50,0	23,0	82,5
ER 40 AX	8 776 37 001	2,0 - 30,0	75,0	1½"	55,0	65,0
ER 40 AX	8 776 57 003	2,0 - 30,0	75,0	2"	23,0	82,5



▶ locking nut

ref.-no.
8 745 99 004



symbolic drawing

▶ further versions on request

* not included in delivery

ZB UT40 7 000

▶ accessories:

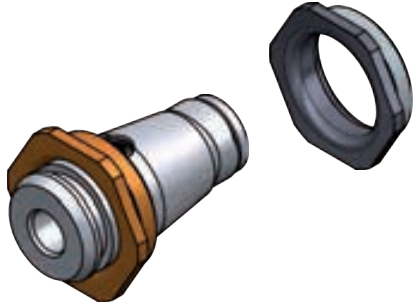

▶ clamping nut

ref.-no.	for change system
8 745 99 005	u-tec 16
8 745 99 006	u-tec 20
8 745 99 007	u-tec 25
8 745 99 008	u-tec 32
8 745 99 009	u-tec 40



▶ snap ring

ref.-no.	for change system
8 706 99 000	u-tec 16
8 706 99 001	u-tec 20
8 706 99 002	u-tec 25
8 706 99 003	u-tec 32
8 706 99 004	u-tec 40



▶ wrench

ref.-no.	for change system
8 796 99 000	u-tec 16
8 796 99 001	u-tec 20
8 796 99 002	u-tec 25
8 796 99 003	u-tec 32
8 796 99 004	u-tec 40



▶ stripper plate

ref.-no.		for change system				
		u-tec 16	u-tec 20	u-tec 25	u-tec 32	u-tec 40
8 796 99 005	small	✓	✓			
8 796 99 006	large			✓	✓	✓



symbolic drawing

▶ further versions on request

heimatec®

● heimatec® - overseas branches

● global representations of heimatec®



headquarters

heimatec® GmbH
Präzisionswerkzeuge
Carl-Benz-Straße 4
D- 77871 Renchen
Postfach 11 36
D- 77867 Renchen

Tel.: +49 (78 43) 94 66 0
Fax: +49 (78 43) 94 66 66
heimatec.de
info@heimatec.de

heimatec® Inc.
USA
usa.heimatec.com
USA@heimatec.com

heimatec®-Ost, JSC
Russia
ru.heimatec.com
Russia@heimatec.com

heimatec® Ltd.
Taiwan
tw.heimatec.com
Taiwan@heimatec.com

heimatec®
Singapore
sg.heimatec.com
Singapore@heimatec.com

heimatec® India Pvt Ltd.
India
in.heimatec.com
India@heimatec.com

